

Laboratory Air-Screen Cleaner

Features:

- Two adjustable brushes
- Interchangeable wire, perforated metal outer cage or other special covers
- Can be used for polishing, hulling and scarifying seed
- Suction fan and filter for dust control
- Two collection trays

Technical Data:

Shipping Weight: 250kg
Power Required: 1550 Watts
Revolutions: 500 – 700rpm,
brush shaft

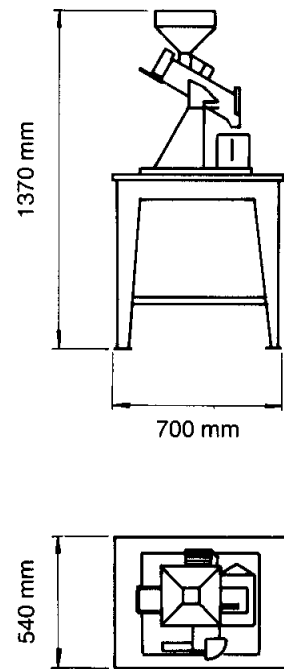

Laboratory Air-Screen Cleaner

Features:

- Rotary shaft with hardened beater bars
- Spring loaded discharge gate
- Agitating scouring action removes beards, awns, white caps and breaks up cluster
- Can serve as feed attachment when mounted on LA-LS cleaning machine
- Can be operated on a continuous or batch basis

Technical Data:

Shipping Weight: 85kg
Power Required: 370 Watts
Revolutions: 1000rpm,
rotor shaft

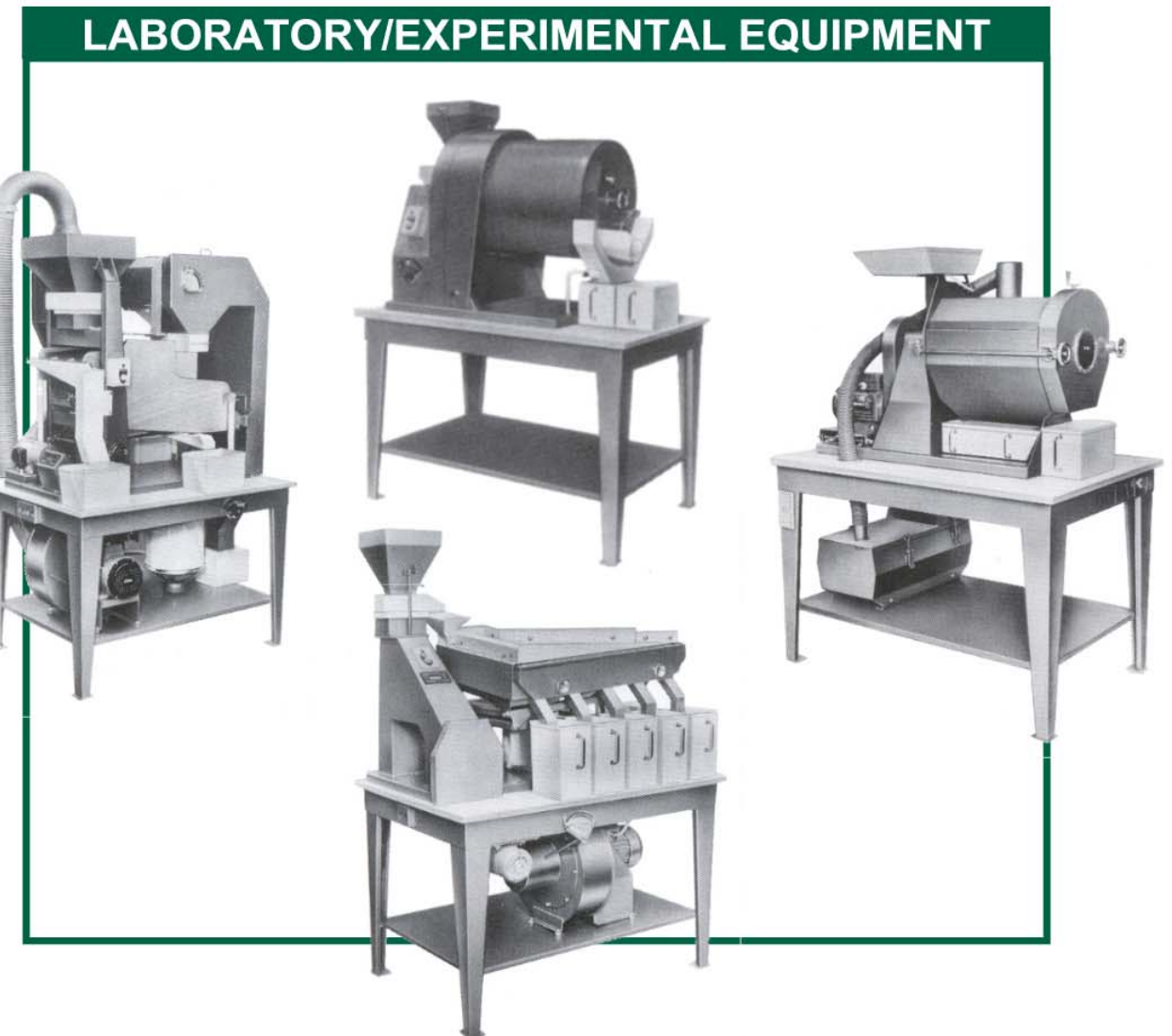

From the comprehensive range of Alvan Blanch high performance Laboratory equipment

In accordance with our policy of continuous development, we reserve the right to change specifications and prices at any time without notice or incurring liability to purchasers. All goods supplied according to our published terms and conditions of sale (copies on application)

DESCRIPTION:

Our line of laboratory/experimental equipment is designed for continuous flow testing of small seed or grain lots to determine foreign material content/volume, sizing, length separating, specific gravity and removal of seed attachments.

OPERATION:

Alvan Blanch equipment operates on a continuous flow (or batch) basis. Small volumes of seed or grain samples can be accurately tested, including small grains, corn, soybeans, cotton, rice, peas, edible beans, sorghum, sunflowers, grasses, vegetables seeds, flower seeds and food grains. Since the equipment is well engineered, you are assured of the same precise results provided by our complete line of production machinery. The sanitary laboratory operation of the equipment has been used successfully by millers, seed conditioners and food processors throughout the world.

FEATURES

- Vibratory feeders for precise feed control
- Collection boxes for each product separation
- Equipped with convenient work stand
- Variable speed motors
- Electrical controls, for connection into your 220V outlet
- Quiet operation
- Easy and quick clean-out
- Calibrated controls

SAMPLE TESTING:

Alvan Blanch also offer you a comprehensive laboratory analysis of your product to make sure you are getting the most precise equipment and screen size for the job. Call or write for technical information, pricing and delivery schedules on our complete product line.

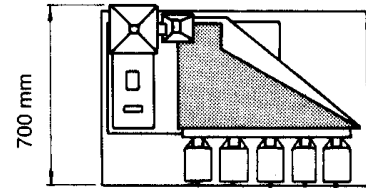
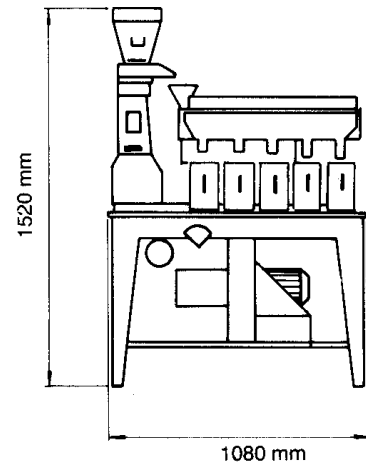
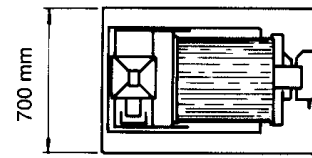
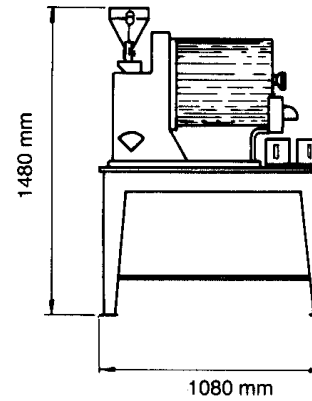
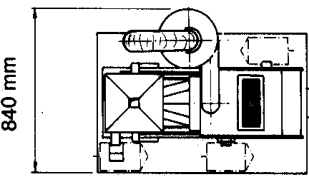
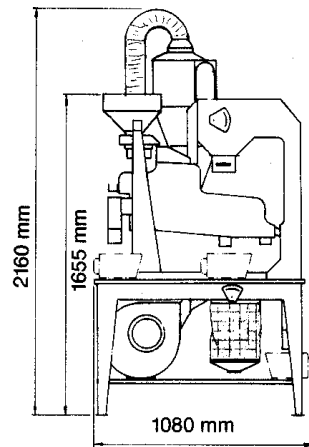

Laboratory Air-Screen Cleaner

Features:

- Pre aspiration and post (screening) aspiration with primary cyclone bag filter for dustless operation
- Three quick-change screen decks, two for oversize material and one for fines material separation. Available in other configurations too.
- The superior, rubber ball screen cleaning mechanism on main screens
- Tachometer to monitor screen agitation
- Continuous cleaning capacity of up to 150kg per hour on wheat

Technical Data:

Shipping Weight: 300kg
 Power Required: 870 Watts
 Revolutions: 0 - 500rpm,
 eccentric shaft

Screen Dimensions

Pre-scalping: 250mm x 250mm
 Main scalping: 250mm x 500mm
 Main sifting: 250mm x 500mm

Laboratory Indented Cylinder Separator

Features:

- Quick change cylinder
- Variable speed cylinder drive
- Vibrating conveyor for liftings discharge
- Two collection trays
- Continuous cleaning capacity of up to 150kg per hour on wheat

Technical Data:

Shipping Weight: 250kg
 Power Required: 90 Watts
 Revolutions: 18 - 40rpm,
 Cylinder size: 400mm x 500mm

Laboratory Gravity Separator

Features:

- Positive pressure deck fan system with air volume throttle
- Interchangeable deck coverings, including 1/3 size for very small lots of material
- Deck pitch, adjustable in both directions
- Adjustable eccentric stroke and length
- Separates material into five product density fractions
- Five collection trays
- Continuous cleaning capacity of up to 100kg per hour on wheat

Technical Data:

Shipping Weight: 250kg
 Power Required: 870 Watts
 Revolutions: 0 - 500rpm,
 eccentric shaft