



ALVAN BLANCH

Processing the World's Crops

WEIGHERS



AB *Continuous batch weighers, available in twin/single compartment models*

AB *Robust but simple construction ensuring reliable operation*

AB *Suitable for agricultural and industrial applications*

AB *For weighing cereals and other granular particles up to 15mm*

AB *Weighers can be linked to system controlling batch weigher*

TECHNICAL DATA

	Twin Compartment Weighers			Single Compartment Weighers	
	KA10	KA25	KA50	B50	B100
Contents per comp. std. Kg	10	25	50	50	100
Contents per comp. min/max, kg	6-12	20-30	40-60	40-60	70-125
Capacity t/h (dry barley)	8	15	25	27	40
Volume per compartment, litres	26	68	130	120	225
Net Weight, Kg	30	52	75	85	142
Accuracy deviation (subject to correct adjustment and operation)	+/-1%	+/-1%	+/-1%	+/-0.5%	+/-0.5%

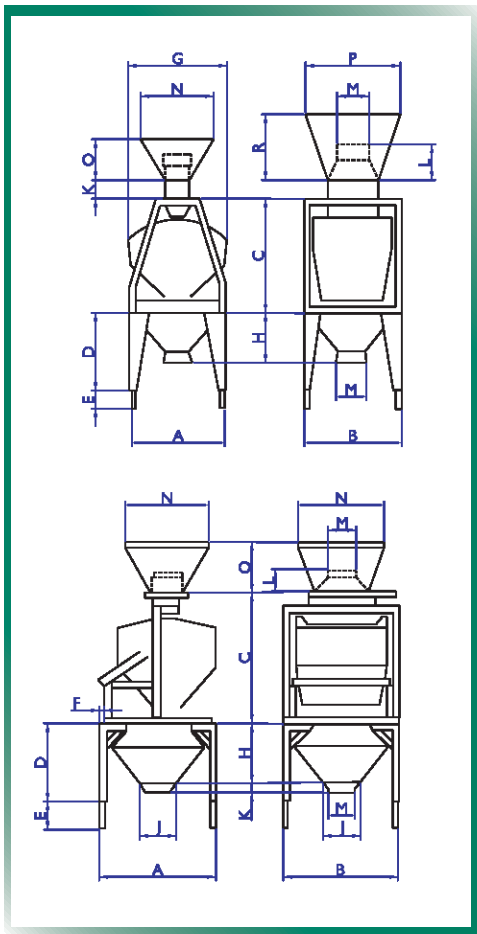

DIMENSIONS (mm)

	KA10	KA25	KA50	B50	B100
A	500	660	800	740	900
B	500	660	810	740	900
C	585	730	840	830	1030
D	400	600	600	600	600
E	0-300	0-400	0-400	0-400	0-400
F	40	40	40	40	50
G	550	720	860		
H	250	350	400	400	485
I				300	300
J					
K	100	100	100	120	120
L	125	125	125	100	150
M	160	160	200	160	200
N	400	400	400	500	670
O	200	200	200	325	380
P	480	480	480		
Q					
R	335	335	335		



In accordance with our policy of continuous development, we reserve the right to change specifications and prices at any time without notice or incurring liability to purchasers. All goods supplied according to our published terms and conditions of sale (copies on application)

AB ALVAN BLANCH
Processing the World's Crops

Chelworth, Malmesbury, Wiltshire, SN16 9SG, England

- T +44 (0) 1666 577 333
- F +44 (0) 1666 577 339
- E info@alvanblanch.co.uk
- W www.alvanblanch.co.uk

