

COMPOST MIXERS



MODEL CM45

- AB** Low level easy fill chute for whole bales
- AB** Breaks peat lumps - avoiding structural damage
- AB** Gentle action yet quick batch turn-around
- AB** Homogeneous mixing - no product separation
- AB** Compact, mobile low profile design
- AB** Raised discharge end - direct feed to potting
- AB** Fully pre-wired, mix and watering timers
- AB** Extra robust build and low maintenance

**The design of the Alvan Blanch Compost Mixer
has been proven to be an unbeatable one for the combination
it offers of the above factors.**

COMPOST MIXERS

Capacity 800 litres to 11,300 litres

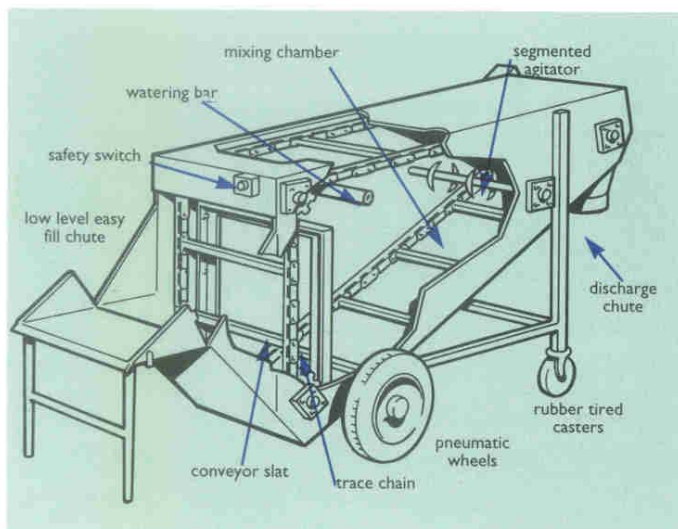

APPLICATION: Alvan Blanch Compost Mixers are ideal for blending a wide range of products of varying densities; peat, heavy earth, soil, bark, grit, fertilizers, minerals etc. Their heavy duty design also makes them suitable for many industrial applications.

Compost Mixers can be used to good effect as self emptying reserve hoppers.

CONSTRUCTION: The shell of the Mixer is robustly constructed in heavy gauge steel (3mm base thickness). The high breaking strain roller chain and slat conveyor runs on cast sprockets mounted on



shafts with sealed bearings. The top of the Mixer is removable for maintenance access. The low level easy fill chute hinges up to form a guard during mixer operation.

An internal watering bar is fitted as standard. Pneumatic wheels and rubber tyred castors allow

ease of movement around the nursery. Fully pre-wired with mounted control panel, the mixer utilizes a 24 volt control circuit for safe operation in the nursery environment. Integral mix and water spray timers are fitted as standard.

In accordance with our policy of continuous development, we reserve the right to change specifications and prices at any time without notice or incurring liability to purchasers. All goods supplied according to our published terms and conditions of sale (copies on application)

OPERATION: All ingredients are introduced to the mixer via the low level easy fill chute which is then hinged up into operational position. A safety lock-out switch ensures that the machine cannot be operated when the low level easy fill chute is open.

The gentle but rapid action from the moving conveyor draws the material up the inclined base of the Mixer, through a segmented agitator, which provides lateral mixing, then the material tumbles backwards down the incline. Batch mixing time can be set to suit product type and condition.

There is no chance of separation occurring during extended mixing time or unloading. Mixed product is discharged from the machine by opening the slides on the outlet chute.

OPTIONAL EQUIPMENT:

Feed/Discharge Mechanisms - to bagging chutes or direct to potting unit/conveyor.

Weighing/Volumetric Batching - complete automatic electronic weighing and volumetric batch control systems.

Dust Control - for complete control of hazardous materials to suit all necessary regulations.

Drives - available with electric (single or three phase), diesel/petrol engine or tractor PTO drive.

Top Inlet Hopper - for bulk loading.

Extra Heavy Duty Versions - with 5 mm thick base and 3 mm sides for highly abrasive materials, heavy earth etc.

Special Versions - to suit clients own requirements can be produced to order.

SPECIFICATIONS						
MODEL	BATCH VOLUME (1)	DRIVE (2)	DIMENSIONS mts (3)			
	Litres	kW	Length (4)	Width (5)	Height	Discharge Height (6)
CM28	800	1.5	2.32	1.33	1.32	0.86
CM45	1,300	2.2	2.9	1.33	1.65	1.06
CM65	1,800	4.0	3.65	1.33	1.84	1.28
CM90	2,500	5.5	3.65	1.65	1.84	1.28
CM150	4,500	7.5	4.15	1.77	3.30	2.44
CM230	6,500	11	4.15	2.40	3.30	2.44
CM400	11,300	15	5.3	2.74	3.95	2.69

NOTES

- (1) Batch volume relates to maximum usable space in the Mixer
- (2) Drive - power requirements are upgraded for extra heavy duty versions.
- (3) Dimensions are nominal.
- (4) Length: with back hopper closed.
- (5) Width: Over drive guard.
- (6) Discharge height: Without discharge chute fitted.
- (7) Further information or advice on applications involving unusual products - consult our Technical Department.

AB ALVAN BLANCH
Processing the World's Crops

Chelworth Malmesbury Wiltshire SN16 9SG England
TELEPHONE: 01666 577333

FACSIMILE: Sales/Admin 01666 577339 Production 01666 577263

TELEX: 44304 ALVANB G